



**MĀORI STANDING  
COMMITTEE**  
*Kia Reretahi Tātau*

# **AGENDA**

## **Māori Partnership Committee Meeting Tuesday, 2 June 2026**

**I hereby give notice that a Māori Partnership Committee Meeting will be held on:**

**Date: Tuesday, 2 June 2026**

**Time: 6:00 pm**

**Location: Supper Room, Waihinga Centre, Texas Street  
Martinborough**

**Janice Smith  
Chief Executive Officer**



**Order Of Business**

<b>1</b>	<b>Karakia Timatanga – Opening .....</b>	<b>4</b>
<b>2</b>	<b>Apologies .....</b>	<b>4</b>
<b>3</b>	<b>Conflicts of Interest .....</b>	<b>4</b>
<b>4</b>	<b>Acknowledgements and Tributes .....</b>	<b>4</b>
<b>5</b>	<b>Public Participation.....</b>	<b>4</b>
<b>6</b>	<b>Actions from Public Participation .....</b>	<b>4</b>
<b>7</b>	<b>Urgent Business.....</b>	<b>4</b>
<b>8</b>	<b>Confirmation of Minutes.....</b>	<b>5</b>
8.1	Minutes of the Māori Partnership Committee Meeting held on 10 March 2026 .....	5
<b>9</b>	<b>Matters Arising from Previous Meetings .....</b>	<b>11</b>
<b>10</b>	<b>Decision Reports from Chief Executive and Staff .....</b>	<b>12</b>
10.1	Chairperson Update .....	12
10.2	MPC Grant Allocations - June 2026 .....	13
<b>11</b>	<b>Karakia Whakamutunga – Closing .....</b>	<b>74</b>

**1 KARAKIA TIMATANGA – OPENING**

Kia hora te marino  
Kia whakapapa pounamu te moana  
Hei huarahi mā tātou i te rangi nei  
Aroha atu, aroha mai  
Tātou i ā tātou katoa  
Hui ē! Tāiki ē!

May peace be widespread  
May the seas be like greenstone  
A pathway for us all this day  
Let us show respect for each other  
For one another  
Bind us all together!

**2 APOLOGIES**

**3 CONFLICTS OF INTEREST**

**4 ACKNOWLEDGEMENTS AND TRIBUTES**

**5 PUBLIC PARTICIPATION**

**6 ACTIONS FROM PUBLIC PARTICIPATION**

**7 URGENT BUSINESS**

## **8 CONFIRMATION OF MINUTES**

### **8.1 MINUTES OF THE MĀORI PARTNERSHIP COMMITTEE MEETING HELD ON 10 MARCH 2026**

**Author:** Lina McManus, Grants and Funding Advisor

**Authoriser:** Janice Smith, Chief Executive Officer

**File Number:** N/A

#### **RECOMMENDATIONS**

1. That the minutes of the Māori Partnership Committee meeting held on 10 March 2026 are confirmed as a true and correct record.

#### **APPENDICES**

**Appendix 1 Minutes of the Māori Partnership Committee Meeting held on 10 March 2026**

**MINUTES OF SOUTH WAIRARAPA DISTRICT COUNCIL  
MĀORI PARTNERSHIP COMMITTEE MEETING  
HELD AT THE SUPPER ROOM, WAIHINGA CENTRE, TEXAS STREET, MARTINBOROUGH  
ON TUESDAY, 10 MARCH 2026 AT 7:00 PM**

- PRESENT:** Cr Andrea Rutene, Ms Karen Mikaera, Mr Mark Fenwick (Deputy Chair), Mr JD Smith, Mr Whitu Karauna, Mayor Fran Wilde, Mr Gillies Baker (Chair), Ms Denise Riwai, Ms Memory Te Whaiti (arrived at 7.17pm)
- APOLOGIES:** Ms Dorothy Whittaker, Cr Simone Baker
- IN ATTENDANCE:** Janice Smith (Chief Executive Officer), Narida Hooper (Pou Māori), Shanin Brider (Community Governance Advisor)
- PUBLIC FORUM:** Nil
- CONDUCT OF BUSINESS:** This meeting was held in the Supper Room, Waihinga Centre, Texas Street, Martinborough and via audio-visual conference. This meeting was live-streamed is available to view on our YouTube channel. The meeting was held in public under the above provisions from 7pm to 8.06pm except where expressly noted.

**OPEN SECTION**

**1 KARAKIA TIMATANGA – OPENING**

The committee opened the meeting with a karakia. The Chief Executive welcomed everyone to the meeting and explained health and safety procedures for the evening.

**2 APOLOGIES**

Apologies were received from Dottie Whittaker and Cr Baker prior to the meeting.

**COMMITTEE RESOLUTION MPC2026/01**

**Moved: Mr M Fenwick**

**Seconded: Ms K Mikaera**

**And resolved:**

That the Māori Partnership Committee accept the apologies from Ms Whittaker and Cr Baker.

**CARRIED**

**3 CONFLICTS OF INTEREST**

No interests were disclosed relating to items on the agenda or interests not already recorded on a relevant register.

**4 ACKNOWLEDGEMENTS AND TRIBUTES**

Cr Rutene acknowledged the passing of Hine Webster, of Hurunui ō Rangi marae. Hine spent a considerable amount of her life caring for the elderly. Condolences to her whānau at this sad time.

**5 PUBLIC PARTICIPATION**

Nil

**6 ACTIONS FROM PUBLIC PARTICIPATION**

Nil

**7 URGENT BUSINESS**

Nil

**8 DECISION REPORTS FROM CHIEF EXECUTIVE AND STAFF****8.1 ELECTION OF CHAIRPERSON AND DEPUTY CHAIRPERSON**

Miss Brider Spoke to this report where the purpose was for the committee to select the voting system to use for their election, then use this system if required for the election of the chair and deputy chair.

Nominations were called for the chair position. Ms Mikaera nominated Mr Baker for the role of chair, which was seconded by Mr Karauna. Mr Gillies accepted this nomination.

Nominations were called for the deputy chair position. Mr Karauna nominated Mr Fenwick which was seconded by Mr Smith. Mr Fenwick accepted this nomination.

With there being one nomination for each position voting was not required.

**COMMITTEE RESOLUTION MPC2026/02****Moved: Cr A Rutene****Seconded: Mr W Karauna**

That the Māori Partnership Committee resolves to:

1. Note the information in the contained report
2. Adopt ~~System A~~ or **System B** to elect its chairperson and deputy chairperson if voting is required in its elections
3. Agree that in the event of a tie, the selection will be by way of toss of coin or drawing of names from a hat (by lot)
4. Elect **Gillies Baker** to be the chairperson and **Mark Fenwick** to be the deputy chairperson of the Māori Partnership Committee.

**CARRIED**

**Chief Executive Janice Smith vacated the seat and Chairperson Gillies Baker resumed the seat.**

**8.2 MĀORI PARTNERSHIP COMMITTEE MEETING SCHEDULE FOR 2026**

Miss Brider Spoke to this report where the purpose was to approve a meeting schedule for 2026.

Cr Rutene raised the differences in scheduling from the previous triennium. Informal meetings and timeframes were discussed by members. The committee advised the start time of 6pm would be more appropriate. It was discussed that meetings could be removed if there was no formal business to conduct.

**COMMITTEE RESOLUTION MPC2026/03****Moved: Mr M Fenwick****Seconded: Ms K Mikaera**

That the Māori Partnership Committee resolve to:

1. Receive the report “Māori Partnership Committee meeting schedule 2026”
2. Agree to meetings in the Town Hall supper room at ~~7pm~~ **6pm** on the following evenings:  
Tuesday 21 April  
Tuesday 2 June  
Tuesday 14 July  
Tuesday 25 August  
Tuesday 6 October  
Tuesday 17 November

**CARRIED****Memory Te Whaiti arrived at 7.17pm****8.3 2026 MĀORI PARTNERSHIP COMMITTEE FUNDING**

Miss Brider spoke to this report where the purpose was to confirm and agree on the 2026 grant funding rounds. Members were advised surplus funding would not roll over each financial year, and it was important allocations were in set rounds to a contestable fund to avoid a surplus occurring. Members asked about the publicising of the funding opportunities available which were explained.

**COMMITTEE RESOLUTION MPC2026/04****Moved: Cr A Rutene****Seconded: Mr JD Smith**

That the Māori Partnership Committee resolve to:

- 1 Receive the “2026 Māori Partnership Committee Funding” report.
- 2 Set one funding round in the 2025/2026 financial year for \$26,517 with applications to open 30 March and close 17 May 2026
- 3 Consider and decide on allocation of these grants at the committee’s 2 June 2026 meeting.
- 4 Set the first of two funding rounds in the 2026/2027 financial year, with the first opening 17 September and closing 25 October 2026. Allocation amount to be publicised following the adoption of the Annual Plan
- 5 Consider and decide upon allocation of these grants at the board’s 17 November 2026 meeting
- 6 Agree to determine future funding rounds once the 2027 meeting schedule has been ratified.

**CARRIED**

#### 8.4 INCOME & EXPENDITURE REPORT

Miss Brider spoke to this report where the purpose was to inform the committee of their delegated budgets and provide an overview of the current financial position.

Members were advised of two funding applications which were approved without the funds being uplifted from April 2025. One of these projects was already complete and the other applicant could not be contacted. It was recommended to the committee that those funds be returned to the main allocation pool for redistribution.

##### COMMITTEE RESOLUTION MPC2026/05

**Moved: Mr M Fenwick**

**Seconded: Ms K Mikaera**

That the Māori Partnership Committee resolve to:

- 1 Receive the "Income and Expenditure" report
- 2 Return the amount of \$1,500 not uplifted by Pirinoa School to the grant funding budget for allocation in line with Council's Grants Policy
- 3 Return the amount of \$1,000 not uplifted by Rangitāne o Wairarapa to the grants funding budget for allocation in line with Council's Grant Policy.

**CARRIED**

#### 8.5 MĀORI POLICY REVIEW

Ms Hooper spoke to this report where the purpose was to inform the committee of the recent review of the Māori Policy.

##### COMMITTEE RESOLUTION MPC2026/06

**Moved: Cr A Rutene**

**Seconded: Mr Baker**

**And resolved:**

That the Māori Partnership Committee:

1. Receive the Draft Māori Policy paper

**CARRIED**

The committee further discussed the need for mana whenua input, and noted the time that had passed between the Māori Standing Committee reviewing and providing recommendations in July 2025, along with the change in landscape of the election, and the retention of the Māori Ward.

Mr Karauna expressed that he didn't believe the policy identified consequences if the requirements of the policy were not complied with.

Members requested a wānanga to kōrero with wider hapū and marae about the draft Māori Policy.

##### COMMITTEE RESOLUTION MPC2026/07

**Moved: Ms K Mikaera**

**Seconded: Cr A Rutene**

That Māori Partnership Committee resolve to:

2 Recommend to Council that the Draft Māori Policy be adopted at the meeting 9 April 2026.

In Favour: Nil

Against: Cr A Rutene, Ms K Mikaera, Mr M Fenwick, Mr JD Smith, Mr W Karauna, Mr Baker, Ms Riwai, Mayor Fran Wilde, and Ms Te Whaiti

**LOST**

**The committee plans to wānanga the policy next month and consider input from mana whenua before providing recommendations to Council. It is expected this will happen at their 2 June meeting. The committee also requested that the Kaitohu Matua, Pou Māori present a draft Strategic Māori Framework that maps why we need it, the roadmap to get there, how much will it cost and how long will it take.**

**9 KARAKIA WHAKAMUTUNGA – CLOSING**

The committee closed the meeting with a karakia.

The meeting closed at 8.06pm

**Confirmed as a true and correct record.**

..... (Chair)

..... (Date)

..... (Chief Executive)

..... (Date)

**9        MATTERS ARISING FROM PREVIOUS MEETINGS**

## 10 DECISION REPORTS FROM CHIEF EXECUTIVE AND STAFF

### 10.1 CHAIRPERSON UPDATE

**Author:** Narida Hooper, Principal Advisor, Māori / Pou Māori

**Authoriser:** Janice Smith, Chief Executive Officer

**File Number:**

#### PURPOSE

To *provide members of* the Māori Partnerships Committee with an overview of key strategic, cultural and governance matters relevant to South Wairarapa District Council's engagement with Māori.

#### EXECUTIVE SUMMARY

This report supports informed discussion, enables members to seek clarification, and strengthens shared understanding to guide effective partnership and decision-making.

The Chair will lead the discussion of kaupapa of significance and invite the Pou Māori to speak to each topic as required

Kaupapa of significance;

- Matariki 2026
- Te tiriti o Waitangi
- Strategic Māori Framework
- Iwi and Marae updates from members

#### RECOMMENDATIONS

1. That *the Māori Partnership Committee* receive the Chairperson's Update Report.

#### APPENDICES

Nil

**10.2 MPC GRANT ALLOCATIONS - JUNE 2026****Author:** Lina McManus, Grants and Funding Advisor**Authoriser:** Janice Smith, Chief Executive Officer**File Number:** N/A**PURPOSE**

The purpose of this report is to provide the board with the grant applications received to the Māori Partnership Committee community grant fund for the June 2026 funding round.

**EXECUTIVE SUMMARY**

- The Māori Partnership Committee initially received four applications in the current funding round, which closed on 17 May 2026. Following discussions with the Chair of the Featherston Community Board (FCB), and in recognition of the oversubscription of funds (more than 25 applications requesting over \$80,000), Council officers sought guidance from the Chair of the Māori Partnership Committee (MPC). Approval was requested to include three additional applications from the FCB grant round that align with MPC Kaupapa and criteria.
- In addition, Pae Tū Mōkai o Tauira was invited to submit a single, more comprehensive application instead of two separate applications.
- An application from Papawai Marae, received after the deadline, was also accepted due to a bereavement.
- The committee has a total of 9 applications to review and \$27,063 to allocate to community groups and individuals in this funding round. The total amount subscribed for funding is \$29,017. The board is asked to consider the applications received and determine the best use of the funding available for allocation.
- Note – The applications included with this report are not conclusive of the details provided by the applicant. The committee has had an opportunity to review all supporting evidence, but for privacy reasons, some pages have not been included in the attached summary of applications included in this report's attachment.

**RECOMMENDATIONS**

Officers recommend that the Māori Partnership Committee:

1. Receive the "Applications to the board's April 2026 funding round" report
2. Accept in full/accept in part/ the application from Hau Ariki Marae for \$3,707 to fund the essential infrastructure upgrades
3. Accept in full/accept in part/ the application from Kahutara School for \$1,400 to fund the Kapa Haka Tutoring Programme

4. Accept in full/accept in part/ the application from the South Wairarapa Working Men's Club for \$1,000 to fund a Matariki event at the Club
5. Accept in full/accept in part/ the application from Pae tū Mōkai o Taurira for \$1,456 to purchase a computer and printer, plus \$7,700 to deliver their school group environmental sessions
6. Accept in full/accept in part/ the application from Fareham for \$1,000 to fund their Community Blessing, Open Day and Matariki Hui
7. Accept in full/accept in part/ the application from Featherston Matariki Events Committee for \$1,500 to fund the Featherston Matariki Festival
8. Accept in full/accept in part/ the application from SMAC Gym for \$5,000 to fund the NZ Nationals Black Gloves team camp hosted in South Wairarapa
9. Accept in full/accept in part/ the application from Papawai Marae for \$4,300 to fund the purchase of bedding, basic kitchen cutlery and garden maintenance.

## BACKGROUND

South Wairarapa District Council is committed to promoting sustainable social, economic, cultural and environmental outcomes within the district. One way to achieve this is to provide community investment via grants to eligible community groups and projects benefiting the people of South Wairarapa.

The Māori Partnership Committee has delegated authority to make financial decisions within the allocated and available budget.

The committee operates its grant fund in accordance with the Council's Grants Policy. The Grants Policy applies to all grants funded by Council, including committees and community boards.

The committee is allocated funding for grants through the Long-Term Plan/Annual Plan. Grant allocations and any expenditure must be made by resolution at a formal meeting.

Under the current Grants Policy, eligibility for community board grants include:

- Community organisations, marae committees, school, an individual, or a group of individuals who have come together for a common purpose to benefit the South Wairarapa.
- Whilst the applicant does not need to be based in the South Wairarapa or the ward from where the funds are being sought, they should be able to demonstrate that the activity benefits the local community.

Under the current Grants Policy, the following allocation principles are applied:

- We are impartial and treat all applicants fairly.
- We operate transparently while protecting applicant's financial confidentiality
- We provide feedback to unsuccessful applicants so they can learn and know how to improve next time.
- We consider the outcomes of previous funding assistance given by Council.

## DISCUSSION

### OPTIONS

The options available to the committee are to fund, partially fund, or decline the applications as they are presented. If declining an application, the committee can request further information from the applicant and accept their application to a future funding round if appropriate, but should consider applicants time constraints.

### CONSIDERATIONS

The Māori Partnerships Committee was allocated like the community boards from the Council's Annual Plan process.

Therefore, the delegation for decision making is with the committee and has no further impact on the Council's AP/LTP, OPEX/CAPEX, rating impact or procurement process.

Applications should align with at least one of the committee's four pou – Tautoko, Te Taiao, Whakapapa and Marae Wawata.

## COMPLIANCE SCHEDULE

Full consideration has been given to the provisions of the Local Government Act 2002 S77 in relation to decision making, in particular:

1. A Local authority must, in the course of the decision-making process,
  - a) Seek to identify all reasonably practicable options for the achievement of the objective of a decision; and
  - b) Assess the options in terms of their advantages and disadvantages; and
  - c) If any of the options identified under paragraph (a) involves a significant decision in relation to land or a body of water, take into account the relationship of Māori and their culture and traditions with their ancestral land, water sites, waahi tapu, valued flora and fauna and other taonga.
2. This section is subject to Section 79 - Compliance with procedures in relation to decisions.

Compliance requirement	Staff assessment
State the level of significance (high or low) of the issue or proposal as determined by the <a href="#">Council's Significance and Engagement Policy</a>	This is a matter of low significance.
State the relevant Council policies (external or internal), legislation, and/or community outcomes (as stated in the Long Term Plan) that relate to this decision.	This report complies with the Grants Policy.
State the possible implications for Māori and how Māori have been provided with	There are no implications for Māori.

an opportunity to contribute to decision making if this decision is significant and relates to land and/or any body of water.	
Chief Financial Officer review	The Chief Financial Officer has not reviewed this report.
State the possible implications for health and safety	None

**APPENDICES****Appendix 1      MPC Grants - June 2026**

# Application for funding

## Māori Partnership Committee



Please make sure you have read the South Wairarapa District Council Funding Policy before completing this form.

You should include as much information as possible with your application so feel free to include additional pages if the space provided is not enough for you to work with.

The Māori Partnership Committee requests applicants to attend the allocation meeting to speak to their applications before decisions are made.

If you have any questions or need assistance filling in this form, please contact Shanin Brider [shanin.briders@swdc.govt.nz](mailto:shanin.briders@swdc.govt.nz) or call 06 306 9611.

Completed application forms can be emailed to [grants@swdc.govt.nz](mailto:grants@swdc.govt.nz)

### CONTACT DETAILS

Name of primary contact	Herewini Ammunson
Organisation	Papawai pa committee
Role/position	Trustee
Organisation address	18 Pah Road, Papawai Greytown 5794
Phone number	0273000141
Email address	Papawai.marae@gmail.com

Name of secondary contact	Tyler Matthews
Role/position	Trustee
Phone number	0272821115
Email address	Matthewstyler954@gmail.com

### PROJECT/EVENT DETAILS

What is the name of your project/event?

-New bedding upgrade for our beautiful wharenui  
 -Basic kitchen cutlery  
 -General maintenance tools

When and where is your project/event taking place?

18 Pah Road, Papawai Greytown

**Tell us a bit about your project/event and what it entails?**

We are wanting to replace our pillows, pillow cases, sheets and fitted sheets in our wharenuī for a more comfortable experience for our whānau, our visitors and our local Tamariki who use our marae. We would also like to add to our basic kitchen items and general maintenance equipment.

**Who is the project/event aimed at? Who is your target audience?**

Our target audience is our kaumatua, our families and friends also local Tamariki that visit from schools and other groups who might book to use our marae

**How many people/volunteers are involved in organising this project/event?**

2

**How many people are you expecting to attend this project/event?**

100

**Please outline how your project/event aligns with one or more of the committee's four Pou.**

(Tautoko, Te Taiao, Whakapapa, and Marae Wawata)

We tautoko our whānau and our community by providing a hub where they can host tangihanga, weddings, birthday celebrations and lots of other events. We also host local Kura and visitors for cultural experiences

[Empty rectangular box]

**How are you planning on measuring the success of your project/event?**

We plan on measuring the success by seeing our whānau and visitors experience a comfortable stay at our wharenuī hopefully resulting in more bookings and whanau engagement moving forward.

**FINANCIAL INFORMATION**

**How much money are you requesting from the Māori Partnership Committee?**

\$4300

**What are you going to spend this money on?**

100 pillows - \$1000  
100 sets of single sheets - \$2500  
Kitchen cutlery - \$500  
Basic tools for maintenance (ladder, garden edger and sprayer) - \$500

**How much money have you raised so far, and who else has contributed financially to this event/project?**

We have some funds allocated to start this project and are in the process of putting a maintenance schedule together to help benefit our marae moving forward.

How much do you anticipate this whole project/event will cost in total?

How much is your own organisation contributing to the event/project?

Have you applied to SWDC for funding in the past, and if so, what for?

We applied in 2022 and received \$9000 to support our kitchen upgrade.

Is your organisation registered for GST?

 Yes  No

GST number if applicable

Please provide the bank account information for your organisation

Account number	01-0682-0266100-00
Name of account holder	Papawai Pa Committee

**ADDITIONAL INFORMATION**

Applications must be accompanied by:

- A detailed project/event budget which outlines income and expense information
- Proof of account – this could be a copy of a statement or screenshot showing account number, name and banking logo
- A copy of your most recent bank statement showing your current financial position.

**PRIVACY STATEMENT**

The personal information within this application is collected and held by South Wairarapa District Council for the purpose of considering your application for financial assistance. You have the right of access to, and correction of, personal information about you that we hold.

This application will be publicly available within the agenda of the appropriate board meeting where applications will be heard and allocated. Your personal information will be redacted to retain privacy.

**DECLARATION**

By signing this application, you agree the information provided is true and correct to the best of your knowledge and you are authorised to make this application on behalf of the organisation. You also agree to account for the funding as per the guidelines set out in the Grants Policy.

Herewini Ammunson

**Signature of primary contact**

31.03.2026

**Date**

Tyler Matthews

**Signature of secondary contact**

31.03.2026

**Date**



7:47
72

7:39
76

7:49
71

**Your Cart (2 items)**

2 Pack Cotton Rich Cover Pillows - Medium Profile, White

\$650.00

50

180 Thread Count Sheet Set - Single Bed, White

\$2376.00

99

Home / Home & Living / 16 Piece Hommered Cutlery Set

**\$22**

★★★★★ 4.8 (5)

SKU: P-43486519

16 Piece Hommered Cutlery Set

Club Deals

Chapin Backpack Sprayer 15 litre

Normal \$119

Club price **\$89** each

SKU: 2033987 M: 79100CH

★★★★★ 5.0 (4) Write a review

**Subtotal** **\$3026.00**

Excluding delivery fees

[Keep shopping](#) [Checkout](#)

[Kmart.co.nz](#)

Chapin Backpack Sprayer 15 litre

Normal \$119

Club price **\$89** each

SKU: 2033987 M: 79100CH

★★★★★ 5.0 (4) Write a review

7

Item 10.2 - Appendix 1

Page 23



7:48

Latest Deals & Offers    Our price guarantee    Scam warning!

Product Recall & Safety Notices - find out more

Shop > Garden > Garden Equipment > Garden Hand Tools > Edgers & Trimmers > Edge Trimmers

**Atlas Trade Trade Drop Forged Disc Edge Trimmer 1140mm**

SKU: 120881 M: AT86614

★★★★★ 1.9 (27) Write a review



Feedback

7:48

Latest Deals & Offers    Our price guarantee    Scam warning!

Product Recall & Safety Notices - find out more

Shop > Building & Hardware > Hardware > Ladders > Ladders > Dual Purpose & Double Sided Ladders

**EXCLUSIVE Werner® Dual Purpose Ladder 6/10 Step Aluminium**

Normal \$195

Club price \$145 each

SKU: 329397 M: DP336ANZ

★★★★★ 4.8 (110) Write a review



Club Deals

Feedback

mitre10.co.nz

mitre10.co.nz



# Application for funding

## Māori Partnership Committee



Please make sure you have read the South Wairarapa District Council Funding Policy before completing this form.

You should include as much information as possible with your application so feel free to include additional pages if the space provided is not enough for you to work with.

The Māori Partnership Committee requests applicants to attend the allocation meeting to speak to their applications before decisions are made.

If you have any questions or need assistance filling in this form, please contact Shanin Brider [shanin.brider@swdc.govt.nz](mailto:shanin.brider@swdc.govt.nz) or call 06 306 9611.

Completed application forms can be emailed to [grants@swdc.govt.nz](mailto:grants@swdc.govt.nz)

### CONTACT DETAILS

<b>Name of primary contact</b>	David McCartney
<b>Organisation</b>	Hau Arika Marae
<b>Role/position</b>	Trustee/Marae Committee member
<b>Organisation address</b>	131 Regent Street, Martinborough, 5711
<b>Phone number</b>	027368456
<b>Email address</b>	hauariki@gmail.com

<b>Name of secondary contact</b>	Les Roberts
<b>Role/position</b>	Marae Committee member
<b>Phone number</b>	0294488444
<b>Email address</b>	gabrieleandles@yahoo.co.nz

### PROJECT/EVENT DETAILS

**What is the name of your project/event?**

Hau Arika Marae Essential Infrastructure Upgrades

**When and where is your project/event taking place?**

Hau Arika Marae, Martinborough.  
Work to be completed within 3–6 months of funding approval.

**Tell us a bit about your project/event and what it entails?**

Hau Ariki Marae is seeking funding to undertake essential maintenance and infrastructure upgrades to ensure the marae can safely and effectively continue to host whānau, hapori and manuhiri.

The primary priority is the urgent replacement of a failed califont that provides hot water to the marae's shower and ablution facilities. One of two existing califonts has reached the end of its serviceable life and is leaking beyond repair. This significantly impacts the marae's ability to accommodate overnight stays and large gatherings.

In addition, there are maintenance issues including repairing a kitchen sink tap and upgrading external flooring/decking outside the accommodation wing (not included in this application) to ensure safety and usability.

Hau Ariki Marae regularly hosts a wide range of activities including tangihanga, wānanga, school visits, community meetings, and cultural development. These upgrades are essential to maintaining a safe, hygienic and functional environment for all users.

**Who is the project/event aimed at? Who is your target audience?**

The marae regularly hosts groups ranging from 10 to 100 people, with ongoing use throughout the year for overnight stays, events, and community activities. The project is aimed at:

- whānau and hapū connected to Hau Ariki Marae
- local schools and rangatahi participating in educational visits
- wider community groups and organisations using the marae
- manuhiri attending tangihanga, hui and cultural events

**8 committee members**

**How many people/volunteers are involved in organising this project/event?**

**100 + per month**

**How many people are you expecting to attend this project/event?**

**Please outline how your project/event aligns with one or more of the committee's four Pou.**

(Tautoko, Te Taiao, Whakapapa, and Marae Wawata)

**Tautoko (support):**

This project supports the ongoing operation of Hau Ariki Marae as a key community hub for cultural, social and community events.

**Te Taiao (environment):**

Upgrading infrastructure ensures efficient use of resources (e.g. modern califont systems) and improves sustainability of facilities.

**Whakapapa:**

Maintaining the marae supports the connection of the Martinborough community to their whenua, tikanga and cultural identity.

**Marae Wawata (aspiration):**

These improvements contribute to the long-term vision of a safe, well-maintained marae capable of hosting community events both now and in the future.

How are you planning on measuring the success of your project/event?

- Restoration of reliable hot water supply for all facilities
- Continued ability to host overnight groups safely
- Increased usability of accommodation areas
- Positive feedback from marae users and visiting groups
- Ongoing use of marae for cultural, educational and community purposes

**FINANCIAL INFORMATION**

\$3,707

How much money are you requesting from the Māori Partnership Committee?

What are you going to spend this money on?

- **1<sup>st</sup> Priority:** Replacement and installation of califont – \$2,897.00
- **2<sup>nd</sup> Priority:** Kitchen tap replacement/installation – \$517.00
- **3<sup>rd</sup> Priority:** Bathroom tap replacement/installation \$293.00

How much money have you raised so far, and who else has contributed financially to this event/project?

We pay to maintain our marae facilities regularly, however, these items have reached the end of their useful life and now require full replacement

\$ 3,707

How much do you anticipate this whole project/event will cost in total?

volunteer time

How much is your own organisation contributing to the event/project?

Have you applied to SWDC for funding in the past, and if so, what for?

Water tanks for resilience  
Heat pump for accommodation block  
Mattresses for manuhiri



Is your organisation registered for GST?

Yes

No

n/a

GST number if applicable

**Please provide the bank account information for your organisation**

Account number	01-0671-0005216-00
Name of account holder	HAU ARIKI MARAE COMMITTEE

**ADDITIONAL INFORMATION**

Applications must be accompanied by:

- A detailed project/event budget which outlines income and expense information *(see breakdown in financial information section)*
- Proof of account – this could be a copy of a statement or screenshot showing account number, name and banking logo *(attached)*
- A copy of your most recent bank statement showing your current financial position. *(attached)*

**PRIVACY STATEMENT**

The personal information within this application is collected and held by South Wairarapa District Council for the purpose of considering your application for financial assistance. You have the right of access to, and correction of, personal information about you that we hold.

This application will be publicly available within the agenda of the appropriate board meeting where applications will be heard and allocated. Your personal information will be redacted to retain privacy.

**DECLARATION**

By signing this application, you agree the information provided is true and correct to the best of your knowledge and you are authorised to make this application on behalf of the organisation. You also agree to account for the funding as per the guidelines set out in the Grants Policy.

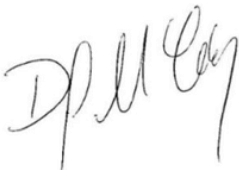

David McCartney

17 May 2026

**Signature of primary contact**

**Date**

Les Roberts

Les Roberts

17 May 2026

**Signature of secondary contact**

**Date**

**Application for funding****Māori Partnership Committee**

Please make sure you have read the South Wairarapa District Council Funding Policy before completing this form.

You should include as much information as possible with your application so feel free to include additional pages if the space provided is not enough for you to work with.

The Māori Partnership Committee requests applicants to attend the allocation meeting to speak to their applications before decisions are made.

If you have any questions or need assistance filling in this form, please contact Shanin Brider [shanin.bridger@swdc.govt.nz](mailto:shanin.bridger@swdc.govt.nz) or call 06 306 9611.

**Completed application forms can be emailed to [grants@swdc.govt.nz](mailto:grants@swdc.govt.nz)**

**CONTACT DETAILS**

<b>Name of primary contact</b>	Ariana Te Whetu
<b>Organisation</b>	Kahutara School
<b>Role/position</b>	Tumuaki/Principal
<b>Organisation address</b>	990 Kahutara Road, Kahutara
<b>Phone number</b>	063088427
<b>Email address</b>	principal@kahutara.school.nz

<b>Name of secondary contact</b>	Stella Chen
<b>Role/position</b>	Board Member
<b>Phone number</b>	0210363337
<b>Email address</b>	stella@kahutara.school.nz

**PROJECT/EVENT DETAILS****What is the name of your project/event?**

*Kapa Haka Tutoring Programme*

**When and where is your project/event taking place?**

*Weekly lessons on Friday from 11:00am - 12:00pm. Keepa Smith is supporting our rōpū this term, and we want to be able to continue this in Term 3 and Term 4.*

**Tell us a bit about your project/event and what it entails?**

*This programme provides ongoing kapa haka tuition to support our tamariki to continue learning and strengthening their knowledge of haka, karakia, waiata, waiata ā-ringa, poi, and mau rākau. It builds directly on the foundations established last year with Lee Flutey, ensuring continuity of learning while also expanding our repertoire with new waiata and haka from across the wider Wairarapa. Through regular tutoring, students deepen their understanding of te reo Māori, tikanga, and the stories behind each item, strengthening their cultural identity, confidence, and connection to place. The programme supports both*

*the preservation of what has already been learned and the growth of new skills and knowledge within our kapa haka group.*

**Who is the project/event aimed at? Who is your target audience?**

*We invite all of our students to be part of our Kapa Haka lessons. At the moment, we have 50 student who join the weekly lessons. Our total school roll is 85.*

**How many people/volunteers are involved in organising this project/event?**

3

**How many people are you expecting to attend this project/event?**

100

**Please outline how your project/event aligns with one or more of the committee's four Pou.**

(Tautoko, Te Taiao, Whakapapa, and Marae Wawata)

*This kapa haka tutor programme strongly aligns with the four pou of the Māori Partnership Committee. It contributes to Tautoko by providing structured support that enables tamariki and rangatahi to access high-quality cultural learning and to develop their skills and confidence in kapa haka. It reflects Te Taiao through strengthening our connection to the natural and spiritual world, expressed through waiata, karakia, haka, waiata ā-ringa and mau rākau, all of which acknowledge and draw upon te taiao and our environment. Through the teaching and continuation of waiata, haka and local histories from across the wider Wairarapa, the programme upholds Whakapapa by deepening understanding of ancestral connections, local stories, and cultural identity. It also supports Marae Wawata by building capability within our school and wider community, enabling tauira to carry tikanga and te reo Māori forward and contribute to the wellbeing and aspirations of our marae and whānau.*

*This mahi is further strengthened by our ongoing connections with local marae. Last year, our kapa haka group experienced their first noho marae at Kohunui Marae, which was a significant and memorable experience for our rōpū. We were also privileged this year to take our senior students to Te Ore Ore Marae to learn about Paora Pōtangaroa and the history of the area. We are committed to continuing and strengthening our relationships with Kohunui Marae and Hau Ariki Marae, as these are the marae to which many of our tamariki have direct whakapapa connections.*

**How are you planning on measuring the success of your project/event?**

*Success of this programme will be measured through a combination of participation, engagement, and growth in confidence and capability. We will track the number of students involved in the rōpū and aim to maintain strong and sustained participation across the year levels. Student engagement will be evident through regular attendance, active involvement in practices, and willingness to take on roles within the group.*

*We will also measure success through increased confidence and performance capability, observed in students' ability to perform haka, waiata, waiata ā-ringa, poi, and mau rākau with accuracy, expression, and pride during both school and community performances. Feedback from kaiako, the tutor, and whānau will also be used to gauge growth in students' confidence, cultural understanding, and sense of identity. Over time, success will be seen in students' ability to stand confidently as part of a group, represent their school and marae connections with pride, and demonstrate increased knowledge of te reo Māori and tikanga within kapa haka contexts.*

**FINANCIAL INFORMATION**

How much money are you requesting from the Māori Partnership Committee?

\$3000

What are you going to spend this money on?

*Tutor fees for Keepa Smith in Term 3 and Term 4, 2026. The total cost of fees for Term 3 and 4 is \$4400. We are applying for \$3000 towards the total cost.*

How much money have you raised so far, and who else has contributed financially to this event/project?

*We have already budgeted for the tutor fees for Kapa Haka in Term 1 and Term 2, 2026 which is separate to this application. We can contribute \$1400 towards the costs for the tutor in Term 3 and Term 4.*

How much do you anticipate this whole project/event will cost in total?

\$4,400

How much is your own organisation contributing to the event/project?

\$1,400

Have you applied to SWDC for funding in the past, and if so, what for?

*In October 2024 we applied for the Community Wellbeing Fund for \$4800. This was approved and we used this to employ Lee Flutey to support our Kapa Haka.*

Is your organisation registered for GST number if applicable

No  Yes  
021-067-180

Please provide the bank account information for your organisation

Account number	12-3290-0003560-00
Name of account holder	Kahutara School Board Education Administration Account

**ADDITIONAL INFORMATION**

Applications must be accompanied by:

- A detailed project/event budget which outlines income and expense information
- Proof of account - this could be a copy of a statement or screenshot showing account number, name and banking logo
- A copy of your most recent bank statement showing your current financial position.

**PRIVACY STATEMENT**

The personal information within this application is collected and held by South Wairarapa District Council for the purpose of considering your application for financial assistance. You have the right of access to, and correction of, personal information about you that we hold.

This application will be publicly available within the agenda of the appropriate board meeting where applications will be heard and allocated. Your personal information will be redacted to retain privacy.

**DECLARATION**

By signing this application, you agree the information provided is true and correct to the best of your knowledge and you are authorised to make this application on behalf of the organisation. You also agree to account for the funding as per the guidelines set out in the Grants Policy.

*A Te Whetu*

Signature of primary contact - Ariana Te Whetu

17/05/2026

Date

*Stella Khoo*

Signature of secondary contact - Stella Khoo

17/05/2026

Date

# Application for funding



## Māori Partnership Committee

Please make sure you have read the South Wairarapa District Council Funding Policy before completing this form.

You should include as much information as possible with your application so feel free to include additional pages if the space provided is not enough for you to work with.

The Māori Partnership Committee requests applicants to attend the allocation meeting to speak to their applications before decisions are made.

If you have any questions or need assistance filling in this form, please contact Shanin Brider [shanin.bridger@swdc.govt.nz](mailto:shanin.bridger@swdc.govt.nz) or call 06 306 9611.

Completed application forms can be emailed to [grants@swdc.govt.nz](mailto:grants@swdc.govt.nz)

### CONTACT DETAILS

Name of primary contact	Lucy Harmon
Organisation	SWWMC
Role/position	Secretary Manager
Organisation address	120 Main Street Greytown
Phone number	027 209 7359
Email address	gm@swwmc.org.nz

Name of secondary contact	Rachel Taylor
Role/position	Bar Manager
Phone number	027 250 5753
Email address	rach.jazz1@gmail.com

### PROJECT/EVENT DETAILS

What is the name of your project/event?

T.B.C.

When and where is your project/event taking place?

Matariki holiday or close too T.B.C.

Tell us a bit about your project/event and what it entails?

Talk on Matariki, but done in a  
 talk around areas of Wairarapa  
 Plus music -  
 Mike Kawana - Speaker  
 + 2 weavers (local) to teach (make Poi, Fox Stars)

Who is the project/event aimed at? Who is your target audience?

Wairarapa Community

How many people/volunteers are involved in organising this project/event?

5

How many people are you expecting to attend this project/event?

50+

Please outline how your project/event aligns with one or more of the committee's four Pou.  
(Tautoko, Te Taiao, Whakapapa, and Marae Wawata)

Whakapapa -  
 Mike talks on all the areas of  
 the Wairarapa - puts it around Matariki  
 All different Marae

How are you planning on measuring the success of your project/event?

By feed back from the members and community. - Advert in local paper.

FINANCIAL INFORMATION

How much money are you requesting from the Māori Partnership Committee?

\$ 800 -

What are you going to spend this money on?

Cover for Mike's expenses plus cover for 2 weavers + materials. + Advertise in local paper.

How much money have you raised so far, and who else has contributed financially to this event/project?

Nil.  
no one has contributed.

How much do you anticipate this whole project/event will cost in total?

\$ 1000 -

How much is your own organisation contributing to the event/project?

\$ ?

yet to find out ✓

Have you applied to SWDC for funding in the past, and if so, what for?

I did with Mstn District Council -  
and we held it a Club Wairarapa.

Is your organisation registered for GST?

Yes  No

GST number if applicable

010 722 748

Please provide the bank account information for your organisation

Account number	01-0623-90061926-000
Name of account holder	South Wairarapa Working Mens Club.

**ADDITIONAL INFORMATION**

Applications must be accompanied by:

- A detailed project/event budget which outlines income and expense information
- Proof of account – this could be a copy of a statement or screenshot showing account number, name and banking logo
- A copy of your most recent bank statement showing your current financial position.

**PRIVACY STATEMENT**

The personal information within this application is collected and held by South Wairarapa District Council for the purpose of considering your application for financial assistance. You have the right of access to, and correction of, personal information about you that we hold.

This application will be publicly available within the agenda of the appropriate board meeting where applications will be heard and allocated. Your personal information will be redacted to retain privacy.

**DECLARATION**

By signing this application, you agree the information provided is true and correct to the best of your knowledge and you are authorised to make this application on behalf of the organisation. You also agree to account for the funding as per the guidelines set out in the Grants Policy.



Signature of primary contact

27/04/26.

Date



Signature of secondary contact

1.05.26.

Date

# Application for funding

## Māori Partnership Committee



Please make sure you have read the South Wairarapa District Council Funding Policy before completing this form.

You should include as much information as possible with your application so feel free to include additional pages if the space provided is not enough for you to work with.

The Māori Partnership Committee requests applicants to attend the allocation meeting to speak to their applications before decisions are made.

If you have any questions or need assistance filling in this form, please contact Shanin Brider [shanin.bridger@swdc.govt.nz](mailto:shanin.bridger@swdc.govt.nz) or call 06 306 9611.

Completed application forms can be emailed to [grants@swdc.govt.nz](mailto:grants@swdc.govt.nz)

### CONTACT DETAILS

Name of primary contact	Jo Clarke
Organisation	Pae tū Mōkai o Tauria Incorporated Society
Role/position	Committee Member
Organisation address	23 North Soldiers Settlement Road, Featherston 5710
Phone number	022 500 4409
Email address	jo@bitwix.com

Name of secondary contact	Karen Mikaera
Role/position	Treasurer
Phone number	027 059 6533
Email address	k.mikaera@gmail.com

### PROJECT/EVENT DETAILS

What is the name of your project/event?

Purchase of computer and printer

When and where is your project/event taking place?

Ongoing administration at Pae Tū Mōkai o Tauria and He Kōtare Native Nursery, 23 North Soldiers Settlement Road, Featherston 5710

**Tell us a bit about your project/event and what it entails?**

Pae Tū Mōkai o Tauria is an Incorporated Society giving Featherston a Māori voice. Toitū te whenua, toitū te moana, toitū te tangata: ‘Heal the land, heal the lake, heal the people’. Our Mission is to:

- provide a strong Māori voice committed to bringing mana to our lives and to the communities that we walk in.
- stand for the revitalisation and sustained kaitiakitanga of Wairarapa Moana and the surrounding natural environment (Te Taiao).
- enable cultural and environmental change through knowledge sharing (wānanga) and collaboration (whakawhanaungatanga).
- share and develop principles (Tikanga) and values (Kawa) that Te Ao Māori bring to our communities.

Society members have “made do” with their own computers until now. It’s time to buy a dedicated computer and printer. He Kōtare Native Nursery has a thriving plant sales business (earning over \$10,000 in the past year) which requires accurate stock levels and payment processing. There are all the usual administration jobs. Staff will use the computer for emails, document and spreadsheet preparation and website maintenance.

**Who is the project/event aimed at? Who is your target audience?**

Our target audience is Wairarapa Moana and her community. We estimate that our work through Te Whare Whakapapa Raranga and He Kōtare Native Nursery reaches 1,500 people.

Te Whare Whakapapa Raranga is an important gathering place for the Pae tū Mōkai o Tauria/Featherston community. The Hangi, Hikoī, Hakari hoki! event in April 2025 succeeded in bringing our community together.

He Kōtare Native Nursery grows native species to improve the poor water quality and mamae/unwellness of the Moana. Planting helps the habitat and will increase native fish and bird populations.

Volunteer weeding and planting events prove the benefit to Māori and non-Māori of Pae tū Mōkai o Tauria/Featherston. In December last year, for example, we supplied 700 at-risk karaihe (Carex buchananii) for the Western Lake Reserve. About fifty volunteers planted them along the foreshore.

**How many people/volunteers are involved in organising this project/event?**

Not applicable

**How many people are you expecting to attend this project/event?**

Not applicable

**Please outline how your project/event aligns with one or more of the committee’s four Pou.**  
(Tautoko, Te Taiao, Whakapapa, and Marae Wawata)

Our Mission Statement above specifically mentions Te Taiao, and He Kōtare nursery explicitly delivers it.

The Nursery is committed to improving the environmental health of the Wairarapa Moana wetlands and to build a strong sense of shared responsibility and connection to the natural world among local residents.

**How are you planning on measuring the success of your project/event?**

A computer and printer are necessary to run the nursery as it grows, especially with plant sales. Success will be measured by our current staff meeting all deadlines and without outside help.

**FINANCIAL INFORMATION**

**How much money are you requesting from the Māori Partnership Committee?**

**What are you going to spend this money on?**

Acer Chromebook 315 CB315-4H-C0BR 15.6" FHD \$457  
 Brother HLL3240CDW Colour Laser Printer \$332 Cartridges (1000 pages) \$105 black + 3 colours at \$125 = \$811. Dimensions 399mm (W) x 399mm (D) x 239mm (H) 15.2kg  
 Tucano Melange Second Skin Sleeve for 15.6" Laptops - Blue \$38.98  
 Delivery \$35.90  
 Prices from www.pbtech.co.nz 2 May 2026 total \$1,356.82. Contingency of \$100 added to allow for price changes.

**How much money have you raised so far, and who else has contributed financially to this event/project?**

**How much do you anticipate this whole project/event will cost in total?**

**How much is your own organisation contributing to the event/project?**

**Have you applied to SWDC for funding in the past, and if so, what for?**

He Kōtare Nursery Development (Potting Sheds), November 2024, \$13,450  
 Hangi, Hikoi, Hakari hoki! April 2025, \$1,800

Is your organisation registered for GST?  Yes  No

GST number if applicable

129780886

Please provide the bank account information for your organisation

Account number	03-0687-0032622-000
Name of account holder	Pae Tū Mōkai O Taurira Inc

#### ADDITIONAL INFORMATION

Applications must be accompanied by:

- A detailed project/event budget which outlines income and expense information
- Proof of account – this could be a copy of a statement or screenshot showing account number, name and banking logo
- A copy of your most recent bank statement showing your current financial position.

#### PRIVACY STATEMENT

The personal information within this application is collected and held by South Wairarapa District Council for the purpose of considering your application for financial assistance. You have the right of access to, and correction of, personal information about you that we hold.

This application will be publicly available within the agenda of the appropriate board meeting where applications will be heard and allocated. Your personal information will be redacted to retain privacy.

#### DECLARATION

By signing this application, you agree the information provided is true and correct to the best of your knowledge and you are authorised to make this application on behalf of the organisation. You also agree to account for the funding as per the guidelines set out in the Grants Policy.

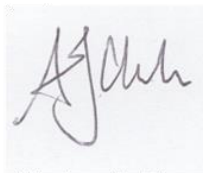

2 May 2026

Signature of primary contact

Date



2 May 2026

Signature of secondary contact

Date



1.5.26

To whom it may concern,

We really enjoyed taking school groups to He Kōtare Native Plant Nursery last year, so they could learn about the work of the nursery which has grown many of the trees Ruamāhanga Farm Foundation has been planting.

These school groups are part of our Te Reo o Te Wai nature education programme where over the course of six field trips children from Kahutara, Martinborough, and Pirinoa schools learn about the Ruamāhanga Awa and the surrounding wetlands and riparian forest. Along with water testing and fish monitoring, children are engaged with native plant restoration. It is both educational and nourishing for the children to see how these native plants begin as tiny eco sourced seeds that are carefully nurtured by the nursery team.

We appreciate the wider work He Kotare Nursery have done the revitalising of Wairarapa Moana. It is impressive they way they have engaged a wide cross section of the community through volunteer events. We also appreciate their Māori kaupapa and that some of their foundation members are Mana Whenua.

We believe this partnership between the Ruamāhanga Farm Foundation is important in raising awareness of the impact the diversion has caused to the health of Wairarapa Moana and the many different ways we can all look after our waterways. For our collaboration in 2026 year, the nursery team have suggested involving the schools we will bring in planting down at the lake edge, which we are excited about.

We would like to offer this letter as our support toward their funding application for the good work they are doing, for both whenua and whanau.

[www.ruamahanga.org.nz](http://www.ruamahanga.org.nz)  
Registered Charity number: CC62761

Ngā mihi mahana

Jane Riddiford  
Co founder Ruamāhanga Farm Foundation

RUAMĀHANGA FARM FOUNDATION  
1415 STATE HIGHWAY 53, MARTINBOROUGH 5783  
[www.ruamahanga.org.nz](http://www.ruamahanga.org.nz)  
Registered Charity number: CC62761

**27**

School group	Group size	Date	Mats and		Staff	Transport	
			Plants	Stakes	Protectors		Hours
Jane R		20 Sept 2026	80	80	80	12	
Jane R		20 Sept 2026	80	80	80	12	
St T		24 Winter 2026	224	224	224	12	
St T		24 Spring 2026				12	
St T		24 Summer 2027				12	
St T		24 Autumn 2027				12	
			384	500 units	500 units	72	
			\$4.07			\$60 per hour	
			\$1,563	\$825	\$877	\$4,320	\$115

Plants	\$1,563
Mats and Stakes	\$825
Protectors	\$877
Staff Time	\$4,320
Transport	\$115
<b>Total</b>	<b><u>\$7,700</u></b>

02/05/2026, 15:26

Shopping Cart - PBTech.co.nz

PB PB Tech
Hardwired
PB PB Business
PB PB Education
PB PB Wholesale
PB PB Government

<
☰
PBTECH
🔍
🛒 7

## SHOPPING CART



**Tucano Melange Second Skin Sleeve for 15.6" Laptops - Blue**

BAGTUC0069

Ships in **1 working day**

Low stock



1

**\$38.98**  
inc GST



**Acer Chromebook 315 CB315-4H-C0BR 15.6" FHD Intel Celeron N4500 - 4GB RAM - 64GB eMMC- ChromeOS - AX WiFi 6 + BT5.1 - Webcam - with Sleeve - 1Y RTB...**  
NBKACN31540I

Ships on **5/05/2026**



1

**\$456.55**  
inc GST

**COMBO DEAL - BUY TOGETHER AND SAVE!**



**Brother HLL-3240CDW Colour Laser Printer 2-Sided Print - Up to 10 Sides Per Minute - Gigabit Ethernet - 5GHz WiFi & USB**

PTRBRT6046805

Ships in **1 working day**



1

**\$331.99**  
inc GST



**Brother TN258BK Toner Cartridge - Black 1000 Pages - for Brother MFCL3755CDW / HLL3240CDW / DCPL3560CDW / HLL8240CDW / MFCL3760CDW / MFCL8390CDW...**

LASBRT0258001

Ships in **1 working day**



1

**\$105.00**  
inc GST



**Brother TN258Y Toner Cartridge - Yellow 1000 Pages - for Brother MFCL3755CDW / HLL3240CDW / DCPL3560CDW / HLL8240CDW / MFCL3760CDW / MFCL8390CDW...**

LASBRT0258002

Ships in **1 working day**

https://www.pbttech.co.nz/basket

**29**



1/3

02/05/2026, 15:26

Shopping Cart - PBTech.co.nz

PB PB Tech
Hardwired
PB PB Business
PB PB Education
PB PB Wholesale
PB PB Government

<
☰
PBTECH
🔍
🛒 7

	<b>HLL3240CDW / DCPL3560CDW / HLL8240CDW / MFCL3760CDW / MFCL8390CDW...</b> LASBRT0258003 🚚 Ships in 1 working day	1	<b>\$124.99</b> inc GST
	<b>Brother TN258C Toner Cartridge - Cyan 1000 Pages - for Brother MFCL3755CDW / HLL3240CDW / DCPL3560CDW / HLL8240CDW / MFCL3760CDW / MFCL8390CDW Printer</b> LASBRT0258004 🚚 Ships in 1 working day	1	<b>\$124.99</b> inc GST

Clear Cart
PB Tech Salesperson: Optional



- Apply Promo Code(s)
- Redeem PB Tech Gift Card

Delivery - Rest of North Island ▼ from \$35.90

**Total** **\$1,356.82**  
 Includes GST of \$176.96  
 Surcharge \$11.68

**Checkout now →**

Customers who bought items in your cart also bought...

 <p> <b>Matthews EKON Premium Quality A4 Office Pri...</b>                  80gsm - 210x297mm - 500 Sheets per Ream - 1 Ream - A             </p>	 <p> <b>Matthews EKON A4 Office Paper - 5 Reams Box 80gsm - Office White - 210x297mm - 500 Sheet...</b> </p>
--	---

<https://www.pbtech.co.nz/basket>

**30**

2/3

02/05/2026, 15:26

Shopping Cart - PBTech.co.nz

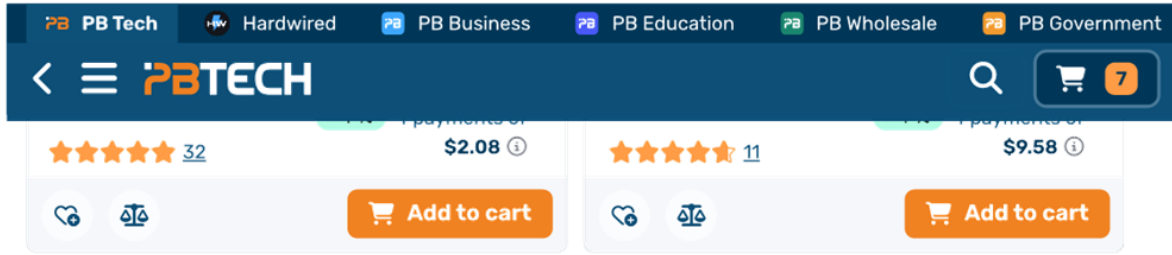

Learn more about [Delivery Options](#), [Pick-up Options](#) and [Payment Methods](#) when shopping online at [www.pbtech.co.nz](http://www.pbtech.co.nz). You can also view our [Help Section](#) for a larger range of topics.

<https://www.pbtech.co.nz/basket>

Kia ora e te whanau,

I am very excited to be able to offer my students the experience of working with the experts at He Kotare Nursery. It is crucial for our ākonga to develop their sense of belonging; of tūrangawaewae. Equally important is developing their connection to nature.

We will do this with He Kōtare Nursery through winter planting at St Teresa's Donald's Creek site. We will visit the Nursery in spring to plant seeds and make seed balls. In summer we will be supported in maintaining the planting at Donald's Creek. In autumn we will take part in seed collection in the bush.

Ngā mihi nui,  
Deb Rei  
Teacher at St. Teresa's Catholic School

# Application for funding

## FEATHERSTON COMMUNITY BOARD



Please make sure you have read the South Wairarapa District Council Funding Policy before completing this form.

You should include as much information as possible with your application so feel free to include additional pages if the space provided is not enough for you to work with.

The Featherston Community Board requests applicants to attend the allocation meeting to speak to their applications before decisions are made.

If you have any questions or need assistance filling in this form, please contact Shanin Brider [shanin.bridger@swdc.govt.nz](mailto:shanin.bridger@swdc.govt.nz) or call 06 306 9611.

Completed application forms can be emailed to [grants@swdc.govt.nz](mailto:grants@swdc.govt.nz)

### CONTACT DETAILS

Name of primary contact	Jo Clarke
Organisation	Pae tū Mōkai o Tauria Incorporated Society
Role/position	Committee Member
Organisation address	23 North Soldiers Settlement Road, Featherston 5710
Phone number	022 500 4409
Email address	jo@bitwix.com

Name of secondary contact	Karen Mikaera
Role/position	Treasurer
Phone number	027 059 6533
Email address	k.mikaera@gmail.com

### PROJECT/EVENT DETAILS

What is the name of your project/event?

School Group Environmental Sessions

When and where is your project/event taking place?

September 2026 at Wairarapa Moana with Kahutara Primary and Martinborough schools

June 2026 – Autumn 2027 at Donald's Creek and He Kōtare Nursery with Saint Teresa's School, Featherston

**Tell us a bit about your project/event and what it entails?**

Pae tū Mōkai o Tairā/Featherston is near the largest wetland in the lower North Island but the area is threatened. We need to raise awareness of the plight of this taonga through education and get our young people interested.

We will run different activities with tamariki to get them comfortable in and engaged with the natural environment. We are partnering with Jane Riddiford of the Ruamāhanga Farm Foundation and with St Teresa’s Featherston, our pilot school. EnviroSchools is helping us design a sustainability project for children.

Activities will include planting at both Wairarapa Moana and Donald’s Creek and making driftwood sculptures. We will teach the cycle of the seasons by planting in winter, seed sowing at the Nursery in spring, then summer plant maintenance, and propagation and seed collecting in autumn.

After the pilot sessions, we can adjust the programme before rolling it out to other South Wairarapa schools.

**Who is the project/event aimed at? Who is your target audience?**

Tamariki at Kahutara Primary and Martinborough schools  
 Tamariki at St Teresa’s School, Featherston

One of our successful cases of youth education was “Life in the Shallows”, a workshop for Years 8 to 11 at Booktown Karukatea in 2023. Other family events include planting days at the Moana and tours of He Kōtare Native Nursery with hands-on experience of plant propagation. This new School Group project carries on that mahi with younger children.

**How many people/volunteers are involved in organising this project/event?** 10

**How many people are you expecting to attend this project/event?** 100

**Please outline how your project/event will contribute to social, cultural, environmental or economic outcomes for our people and places?**

On planting days we have visible support from adults for our work to protect and restore Wairarapa Moana. This new project will draw in the children of our community. Our one-off sessions will get tamariki to the lakeside, while the repeat, seasonal sessions hope to inspire them to see themselves as part of the environment. In their lifetimes they will be able to restore the habitat and watch native species thrive.

**How are you planning on measuring the success of your project/event?**

We will get feedback from teachers. They are the best judges of the benefit to and involvement of the students. For the one-off events, would they recommend a repeat next year? For the seasonal sessions, how many tamariki are keen to come again?

We expect some great reactions from tamariki on the day which we will capture as quotations or a Word Cloud.

**FINANCIAL INFORMATION**

**How much money are you requesting from the Featherston Community Board?**

**\$7,700**

**What are you going to spend this money on?**

We need to cover the costs of plants themselves and the protectors, stakes and mats to give the natives the best chance of survival.

Most of the grant is for payment of our nursery staff. They will spend significant time before each session preparing plants and visiting sites to make sure that the day will be productive. They will discuss with teachers how to run the event to best effect and safely.

Our staff will lead each session, responding to the students’ curiosity and the weather on the day. Afterwards they will write up the project for the kura and as a resource to encourage other schools to join next season.

**How much money have you raised so far, and who else has contributed financially to this event/project?**

This is a new project which we hope the Featherston Community Board will fund in full.

**How much do you anticipate this whole project/event will cost in total?**

**\$7,700**

**How much is your own organisation contributing to the event/project?**

**\$0**

**Have you applied to SWDC for funding in the past, and if so, what for?**

He Kōtare Nursery Development (Potting Sheds), November 2024, \$13,450  
 Hangi, Hikoi, Hakari hoki! April 2025, \$1,800

Is your organisation registered for GST?  Yes  No

GST number if applicable

129780886

Please provide the bank account information for your organisation

Account number	03-0687-0032622-000
Name of account holder	Pae Tū Mōkai O Tairā Inc

#### ADDITIONAL INFORMATION

Applications must be accompanied by:

- A detailed project/event budget which outlines income and expense information
- Proof of account – this could be a copy of a statement or screenshot showing account number, name and banking logo
- A copy of your most recent bank statement showing your current financial position.

#### PRIVACY STATEMENT

The personal information within this application is collected and held by South Wairarapa District Council for the purpose of considering your application for financial assistance. You have the right of access to, and correction of, personal information about you that we hold.

This application will be publicly available within the agenda of the appropriate board meeting where applications will be heard and allocated. Your personal information will be redacted to retain privacy.

#### DECLARATION

By signing this application, you agree the information provided is true and correct to the best of your knowledge and you are authorised to make this application on behalf of the organisation. You also agree to account for the funding as per the guidelines set out in the Grants Policy.

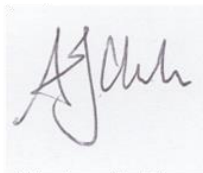

2 May 2026

Signature of primary contact

Date



2 May 2026

Signature of secondary contact

Date

# Application for funding

## FEATHERSTON COMMUNITY BOARD



Please make sure you have read the South Wairarapa District Council Funding Policy before completing this form.

You should include as much information as possible with your application so feel free to include additional pages if the space provided is not enough for you to work with.

The Featherston Community Board requests applicants to attend the allocation meeting to speak to their applications before decisions are made.

If you have any questions or need assistance filling in this form, please contact Shanin Brider [shanin.bridger@swdc.govt.nz](mailto:shanin.bridger@swdc.govt.nz) or call 06 306 9611.

Completed application forms can be emailed to [grants@swdc.govt.nz](mailto:grants@swdc.govt.nz)

### CONTACT DETAILS

Name of primary contact	Jeanette Wheeler
Organisation	Fareham
Role/position	Owner
Organisation address	80 Underhill Road, Featherston
Phone number	0210770946
Email address	Jennywheeler9750@gmail.com

Name of secondary contact	Maureen Hyett
Role/position	Owner
Phone number	0273707754
Email address	Mhyett2@gmail.com

### PROJECT/EVENT DETAILS

What is the name of your project/event?

Fareham House Community Blessing, Open Day and Matariki Community Hui

When and where is your project/event taking place?

The events will take place across June–July 2026 at Fareham House.

The project includes:

1. A public community blessing and open day for Fareham House and whenua
2. A follow-up Matariki strategic community hui focused on future community aspirations, connection and resilience

**Tell us a bit about your project/event and what it entails?**

Fareham House is a historically and socially significant community space within Paetūmokai Featherston that is currently undergoing a community-led reset and reimagining process.

This application seeks support for two linked community events that acknowledge the past while dedicating the site toward a renewed future of service, connection and wellbeing for the local community.

The kaupapa is grounded in Ka mua, ka muri — walking backwards into the future.

The first event will be a public blessing and open day hosted by Fareham Whānau in partnership with mana whenua and community members. The blessing will acknowledge the history of the house and whenua, honour those who have contributed to the site over time, and mark a formal dedication of the space toward the uplifting of the community of Paetūmokai Featherston.

The event will include:

- mana whenua-led blessing of house and whenua
- sharing of local history and stories
- community kōrero and reconnection
- foyer displays and historical photographs
- waiata and cultural contribution
- hosted kai for attendees
- opportunities for neighbours, whānau and community organisations to reconnect with the site

The second event will be a Matariki strategic community hui held following the blessing. This hui will bring together local people, whānau, organisations and community leaders to discuss future aspirations for the site and wider community wellbeing initiatives.

Importantly, the future direction for Fareham House is being shaped alongside community through ongoing kōrero, relationship building and participation.

Together, these events represent both a cultural acknowledgement and a practical next step toward creating a more connected, resilient and community-serving space.

**Who is the project/event aimed at? Who is your target audience?**

The events are aimed at:

- local residents and neighbours
- mana whenua
- whānau connected to Fareham House
- community organisations and volunteers
- local leaders
- tamariki and rangatahi
- former users of the space
- the wider Featherston / Paetūmokai community

**How many people/volunteers are involved in organising this project/event?****38**

Approximately 10–15 volunteers and community supporters are contributing to planning, preparation, hosting and coordination.

**How many people are you expecting to attend this project/event?**

Combined attendance across both events is expected to be approximately 120–170 people.

**Please outline how your project/event will contribute to social, cultural, environmental or economic outcomes for our people and places?**

This project will contribute strongly to social and cultural wellbeing outcomes within Featherston by:

- strengthening local relationships and social cohesion
- reconnecting community members with an important local site
- supporting whakawhanaungatanga through shared kai and storytelling
- honouring local history, identity and whenua
- strengthening relationships with mana whenua
- creating opportunities for greater community participation and volunteering
- supporting community-led planning and future visioning
- encouraging a more connected and resilient local community

Fareham House has long held significance within the community, and this process represents an intentional reset and dedication of the space toward deeper service to local people and future generations.

The project also creates a visible and positive activation of a valued community asset while supporting a more collaborative and participatory approach to local community development.

**How are you planning on measuring the success of your project/event?**

Success will be measured through:

- attendance and diversity of participation
- level of community engagement and contribution
- feedback from attendees and mana whenua
- strengthened relationships and partnerships
- participation in future activities connected to Fareham House
- ideas and initiatives emerging from the Matariki strategic hui

**FINANCIAL INFORMATION**

**How much money are you requesting from the Featherston Community Board?**

\$1,000

**What are you going to spend this money on?**

**Hui 1: Fareham House Community Blessing and Open Day**  
**Hui 2: Matariki Community Hui**

Expense	Hui 1	Hui 2	Total Cost
Kai for blessing/open day	\$250	\$250	\$500
Kai for Matariki strategic hui	\$250	\$250	\$500
Koha for mana whenua / cultural contributors / facilitators	\$300	\$300	\$600
Printing, historical displays and signage	\$200	\$200	\$400
<b>TOTAL</b>	<b>\$1,000</b>	<b>\$1,000</b>	<b>\$2,000</b>

**How much money have you raised so far, and who else has contributed financially to this event/project?**

Fareham Whānau will contribute \$1,000 Fareham Whānau and community supporters are contributing significant in-kind support including:

- event coordination
- hosting
- setup and pack-down
- historical research and displays
- volunteer labour
- community outreach and invitations
- planning and facilitation

**How much do you anticipate this whole project/event will cost in total?**

\$2,000

**How much is your own organisation contributing to the event/project?**

\$1,000

Have you applied to SWDC for funding in the past, and if so, what for?

No

Is your organisation registered for GST?

Yes  No

GST number if applicable

123-181-867

Please provide the bank account information for your organisation

Account number	01 0505 0843580 00
Name of account holder	M M Hyett & J E Wheeler

**ADDITIONAL INFORMATION**

Applications must be accompanied by:

- A detailed project/event budget which outlines income and expense information
- Proof of account – this could be a copy of a statement or screenshot showing account number, name and banking logo
- A copy of your most recent bank statement showing your current financial position.

**PRIVACY STATEMENT**

The personal information within this application is collected and held by South Wairarapa District Council for the purpose of considering your application for financial assistance. You have the right of access to, and correction of, personal information about you that we hold.

This application will be publicly available within the agenda of the appropriate board meeting where applications will be heard and allocated. Your personal information will be redacted to retain privacy.

**DECLARATION**

By signing this application, you agree the information provided is true and correct to the best of your knowledge and you are authorised to make this application on behalf of the organisation. You also agree to account for the funding as per the guidelines set out in the Grants Policy.

[Signature box for primary contact]

Signature of primary contact

[Date box for primary contact]

Date

[Signature box for secondary contact]

Signature of secondary contact

[Date box for secondary contact]

Date

**Budget for 2 x hui:****Hui 1: Fareham House Community Blessing and Open Day****Hui 2: Matariki Community Hui**

<b>Expense</b>	<b>Hui 1</b>	<b>Hui 2</b>	<b>Total Cost</b>
Kai for blessing/open day	\$250	\$250	\$500
Kai for Matariki strategic hui	\$250	\$250	\$500
Koha for mana whenua / cultural contributors / facilitators	\$300	\$300	\$600
Printing, historical displays and signage	\$200	\$200	\$400
<b>TOTAL</b>	<b>\$1,000</b>	<b>\$1,000</b>	<b>\$2,000</b>

**Application for funding****FEATHERSTON COMMUNITY BOARD**

Please make sure you have read the South Wairarapa District Council Funding Policy before completing this form.

You should include as much information as possible with your application so feel free to include additional pages if the space provided is not enough for you to work with.

The Featherston Community Board requests applicants to attend the allocation meeting to speak to their applications before decisions are made.

If you have any questions or need assistance filling in this form, please contact Shanin Brider [shanin.briderswdc@govt.nz](mailto:shanin.briderswdc@govt.nz) or call 06 306 9611.

**Completed application forms can be emailed to [grants@swdc.govt.nz](mailto:grants@swdc.govt.nz)**

**CONTACT DETAILS**

<b>Name of primary contact</b>	Warren Maxwell
<b>Organisation</b>	Featherston Matariki Events Committee
<b>Role/position</b>	Co-Coordinator
<b>Organisation address</b>	39 Boundary Rd Featherston
<b>Phone number</b>	0212274127
<b>Email address</b>	<a href="mailto:tu.te.harakeke@gmail.com">mailto:tu.te.harakeke@gmail.com</a>

<b>Name of secondary contact</b>	Rachel Ammunson
<b>Role/position</b>	Co-Coordinator
<b>Phone number</b>	0276086422
<b>Email address</b>	<a href="mailto:rachelfcooper@gmail.com">mailto:rachelfcooper@gmail.com</a>

**PROJECT/EVENT DETAILS**

**What is the name of your project/event?**

Featherston Matariki Festival 2026.  
[https://www.facebook.com/FeatherstonMatariki/photos\\_by](https://www.facebook.com/FeatherstonMatariki/photos_by)

**When and where is your project/event taking place?**

Each year, our Matariki Festival is held around Featherston township over the weekend of July 9-11. Karakia is held at the Card Reserve 5am in the morning. The children's 'Star Hunt' encourages children

to go into Featherston shops to find the hidden 'Matariki Stars' where they are given a stamp. They need to collect all 9 stamps to get a prize. The hangi is cooked at St Teresa's school and then transported to the ANZAC Hall, train rides at Clifford Square, we visit the cemetery on the Sunday and finish at the RSA on Sunday night with the Featherston Vinyl Club.

**Tell us a bit about your project/event and what it entails?**



Kia whakarongo ake au  
ki te tangi a te manu nei  
a te Matui  
Tu-i, Tu-i, Tuituia  
Tuia i runga  
Tuia i raro  
Tuia i waho  
Tuia i roto  
Tuia i te here tangata

Ka rongo te po!  
Ka rongo te ao!

Tuia e te muka tangata

I takea mai i Hawaikinui  
I Hawaikiroa  
I Hawaikipamamao  
Te Hono i wairua  
Ki te Whaiao  
Ki te Ao Marama  
Tihe Mauriora!

The very senses of my body  
are drawn to the cry of a bird  
It is the Matui  
Calling tu-i, tu-i, tuituia  
That it be woven above  
That is be enmeshed below  
That it be entwined without  
That it be embraced within  
Interlaced as with the threads of  
humanity  
Let it be sensed in the night  
Let it be felt in the light of  
day  
Let it be embodied in the image of all  
being  
Born of the Great Hawaiki  
Born of the Long Hawaiki  
Born of the Distant Hawaiki  
From the merging of the spirits  
Out into the light  
Into the world of light  
Behold the essence of life, the ethos of  
life,  
The principle of life  
Tihe Mauriora!

### Featherston Matariki 2026

In July of 2026, the town of Featherston (Paetumokai) will acknowledge and celebrate our official national holiday of Matariki along with the rest of Aotearoa. This will be the 7th consecutive year that Featherston will have celebrated the revitalisation of this ancient temporal marker of the lunar calendar (Maramataka). These celebrations have provided the wider community an opportunity to connect with Te Ao Māori perspectives to celebrate our diverse, multi-cultural town.

Event objectives include wide community engagement, mātauranga Māori knowledge sharing through story-telling, kapahaka and fun for all residents and participants living in Featherston and South Wairarapa. Children have been introduced to Manu tukutuku (kite) making, local Pūrakau have been shared by Mana Whenua, Taonga Pūoro concerts, stalls, music, artworks and many other activities have been embraced by our small Wairarapa township. With a growing acknowledgement of Te Ao Māori and mātauranga Māori (Māori knowledge and epistemologies), the Featherston Matariki Events Group (FMEG) are looking to expand on what has already been established to make our Featherston Matariki Event a time of tūhonotanga (connection) to both celebrate mātauranga Māori and develop stronger cultural awareness within our community.

### Who is the Featherston Matariki Events Group?

The Featherston Matariki Events Group (FMEG) are a group of Featherston residents, Kaupapa Māori Committee members, Teachers, Wairarapa Gateway business owners, Featherston Booktown members, School Principals, Library, local clubs, parents and FCB representatives who want to see Featherston flourish culturally and economically as a growing provincial town in the beautiful Wairarapa.

The group formed in 2019 as a response to the growing interest in Matariki as a time for reflection and celebration. While other Wairarapa towns explore a more *consumer* driven path of 'Mid-winter Xmas' potentials, FMEG took a more relevant Cultural direction and started to celebrate Matariki instead; resulting in positive community feedback and mana enhancing connections.

The core FMEG committee is largely made of a range of community members who, as previously stated, are passionately supportive of this Matariki kaupapa and who want to see Featherston flourish and be culturally enriched.

### Who is the project/event aimed at? Who is your target audience?

Our Matariki Event has a localised focus that celebrates residents of Featherston town and the wider rural community. Last year we also had events that included Pirinoa and School. Our main event is the shared hangi where anyone is welcome to come to the ANZAC hall and sit down to share a meal together. We usually have around 300 – 400 people join us; either at the Hangi, Hautapu, Star Hunt or cemetery event where we remember our loved ones passed.



Matariki Hangi at ANZAC Hall, 2024

**How many people/volunteers are involved in organising this project/event?**

40 (approx)

**How many people are you expecting to attend this project/event?**

600 (approx)

**Please outline how your project/event will contribute to social, cultural, environmental or economic outcomes for our people and places?**

This annual Festival celebrates the rich social, cultural, environmental and educational aspects of our community. Through knowledge sharing we develop understanding of other cultural perspectives, including taiao (environmental) considerations. Through shared kai we weave a stronger social cohesion within communities. Through shared experiences we grow and inspire manaakitanga. Because this is a community event, there isn't the desire for fiscal profiteering. However, the event does draw public engagement which has a positive fiscal 'osmosis' effect on local businesses.

**How are you planning on measuring the success of your project/event?**

The success of this event is measured by verbal and visual feedback we get from our patrons and whanau. This year we will be including a community survey and suggestions form as an activity for whanau who attend the hangi. Planning for the year ahead is a big part of Matariki, so we are also looking to include a community exercise around Emergency Responsiveness. As a teacher at Kuranui high school, I see long term community and social benefits with Matariki now being normalised as a part of the yearly calendar and students understand what the occasion is about.



*Paetumokai school students experience the 'Matariki Star Mat' 2024.*



*Featherston Community Waiting for the hangi! 2024*



*Combined Featherston Primary Schools perform for Matariki Festival.*



*Taonga Puoro workshop - Matariki Festival 2022*



*Shop Frontage Featherston 2022*



*Mini Fell Trains, 2022.*



*Kite Making@Paetumokai School 2022*

**FINANCIAL INFORMATION**

**How much money are you requesting from the Featherston Community Board?**

**\$1500**

**What are you going to spend this money on?**

This grant will be spent on protein for the hangi (supplied from local businesses). The cost of kai has risen exponentially over the past couple of years and we would be struggling to feed everybody. We aim to feed around 300 people. We do ask local farmers for donated goods but times are getting tougher.

**How much money have you raised so far, and who else has contributed financially to this event/project?**

We have \$944 in our bank account. This has mostly been donations given to us from people after our hangi. Surplus from each event goes towards building the festival for the following year e.g. procuring more materials for kids art activities, glow artworks for the night trains etc.



*He taniwha!! Glow in the dark 2022.*



*Phosphorous glow in the dark Sting rays 2022.*

How much do you anticipate this whole project/event will cost in total?

How much is your own organisation contributing to the event/project?

**Have you applied to SWDC for funding in the past, and if so, what for?**

Yes. We have been successful in securing funding from SWDC for the past 2 years. Each time we have applied for the same amount (\$1000) to cover the cost of meat in order for us to provide the free hangi. Other costs include hall hire, media costs (signs and pamphlets), art supplies for kids activities, material for Glow-in-the-Arts walk, misc hangi supplies. Our goal is to become self-sufficient and to eventually grow our own food for the hangi including our own protein.

Is your organisation registered for GST?  Yes  No  
 GST number if applicable

**Please provide the bank account information for your organisation**

Account number	38-9010-0538729-00
Name of account holder	PaetumokaiCharitableTrust

**ADDITIONAL INFORMATION**

Applications must be accompanied by:

- A detailed project/event budget which outlines income and expense information
- Proof of account – this could be a copy of a statement or screenshot showing account number, name and banking logo
- A copy of your most recent bank statement showing your current financial position.

**PRIVACY STATEMENT**

The personal information within this application is collected and held by South Wairarapa District Council for the purpose of considering your application for financial assistance. You have the right of access to, and correction of, personal information about you that we hold.

This application will be publicly available within the agenda of the appropriate board meeting where applications will be heard and allocated. Your personal information will be redacted to retain privacy.

**DECLARATION**

By signing this application, you agree the information provided is true and correct to the best of your knowledge and you are authorised to make this application on behalf of the organisation. You also agree to account for the funding as per the guidelines set out in the Grants Policy.

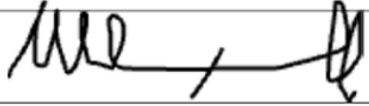

**Signature of primary contact**

13 May 2026

**Date**

  
13.5.26

**Signature of secondary contact**  
**Date**

# Application for funding

## FEATHERSTON COMMUNITY BOARD



Please make sure you have read the South Wairarapa District Council Funding Policy before completing this form.

You should include as much information as possible with your application so feel free to include additional pages if the space provided is not enough for you to work with.

The Featherston Community Board requests applicants to attend the allocation meeting to speak to their applications before decisions are made.

If you have any questions or need assistance filling in this form, please contact Shanin Brider [shanin.brider@swdc.govt.nz](mailto:shanin.brider@swdc.govt.nz) or call 06 306 9611.

Completed application forms can be emailed to [grants@swdc.govt.nz](mailto:grants@swdc.govt.nz)

### CONTACT DETAILS

Name of primary contact	Victoria Parr
Organisation	SMAC Featherston / NZ Blackgloves
Role/position	NZ National Head Coach
Organisation address	74 Fox St Featherston
Phone number	027 707 6230
Email address	smacfeatherston@gmail.com

Name of secondary contact	Quentin Parr
Role/position	HIGH PERFORMANCE COACH
Phone number	021456301
Email address	Quentin@hikitanga.nz

### PROJECT/EVENT DETAILS

What is the name of your project/event?

NZ Blackgloves National team camp hosted by SMAC Wairarapa

When and where is your project/event taking place?

JULY 4TH & 5TH  
The training for Muaythai is held at SMAC Wairarapa. There will be 10km road runs, an introduction to the "One Tree Hill" run, we would also look to collaborate with The Sports Hub, once we firm the date.

**54**

**Tell us a bit about your project/event and what it entails?**

For the fourth consecutive year, I am proud to serve as the New Zealand National Head Coach for the NZ Blackgloves team. Following selection of our National and Development Teams for the 2026 World Championships in Greece, we will deliver two national training camps bringing together approximately 40 athletes and coaching staff from across New Zealand. These camps provide essential preparation through technical training, team development, athlete wellbeing, and building a strong high-performance culture.

We are especially proud to have two junior representatives from South Wairarapa selected this year, highlighting the continued growth and development pathways within our programme for young New Zealand athletes.

Funding support will assist with accommodation, meals, and camp costs, helping reduce financial pressure on athletes and families while ensuring our team can prepare together to proudly represent New Zealand on the world stage.

**Who is the project/event aimed at? Who is your target audience?**

For the fourth consecutive year, I am proud to serve as the New Zealand National Head Coach for the NZ Blackgloves team. Following selection of our National and Development Teams for the 2026 World Championships in Greece, we will deliver two national training camps bringing together approximately 40 athletes and coaching staff from across New Zealand. These camps provide essential preparation through technical training, team development, athlete wellbeing, and building a strong high-performance culture.

We are especially proud to have two junior representatives from South Wairarapa selected this year, highlighting the continued growth and development pathways within our programme for young New Zealand athletes.

Funding support will assist with accommodation, meals, and camp costs, helping reduce financial pressure on athletes and families while ensuring our team can prepare together to proudly represent New Zealand on the world stage.

**How many people/volunteers are involved in organising this project/event?**

Up to 10

**How many people are you expecting to attend this project/event?**

Near 100 all together

**Please outline how your project/event will contribute to social, cultural, environmental or economic outcomes for our people and places?**

This project will deliver positive social and community outcomes by bringing together athletes, families, coaches, and supporters from diverse backgrounds in a safe and supportive environment. The camps promote health, wellbeing, discipline, teamwork, and leadership while providing young people with positive role models and pathways into sport and high performance.

The event will also create cultural and community connections by encouraging local engagement and giving the Featherston community an opportunity to meet and support New Zealand representative athletes. Having national athletes visible within the community helps inspire local youth and strengthens community pride.

Economically, hosting the camps will support local accommodation providers, food suppliers, and small businesses through the use of local services and facilities during the training weekend.

**How are you planning on measuring the success of your project/event?**

Success will be measured through strong athlete participation, successful delivery of both training camps, positive feedback from athletes and families, and improved preparation for the 2026 World Championships. We also aim to create positive community engagement within Featherston, inspire local youth, support our junior representatives, and reduce financial barriers for athletes and families through funding support.

**FINANCIAL INFORMATION**

**How much money are you requesting from the Featherston Community Board?**

\$000

**What are you going to spend this money on?**

Fund support will go to:  
Resource including koha for various workshops & their trainers  
All admin, marketing and equipment  
Noho provides breakfast, lunch and dinner for 1 day, breakfast and lunch for the 2nd day.  
Accommodation for out of town volunteers  
1 x airfare & accomodation of our guest trainer from Auckland.

**How much money have you raised so far, and who else has contributed financially to this event/project?**

Our National Federation contributes \$500 to each camp. The balance of the costs falls back on our athletes, and hosting gym.

Funding support would help bring the costs for our athletes to a minimum.

**How much do you anticipate this whole project/event will cost in total?**

\$000

**How much is your own organisation contributing to the event/project?**

\$

**56**

Have you applied to SWDC for funding in the past, and if so, what for?

No

Is your organisation registered for GST?  Yes  No

GST number if applicable

Please provide the bank account information for your organisation

Account number	38-9027-0449351-00
Name of account holder	SMAC Muaythai Gym Inc

**ADDITIONAL INFORMATION**

Applications must be accompanied by:

- A detailed project/event budget which outlines income and expense information
- Proof of account – this could be a copy of a statement or screenshot showing account number, name and banking logo
- A copy of your most recent bank statement showing your current financial position.

**PRIVACY STATEMENT**

The personal information within this application is collected and held by South Wairarapa District Council for the purpose of considering your application for financial assistance. You have the right of access to, and correction of, personal information about you that we hold.

This application will be publicly available within the agenda of the appropriate board meeting where applications will be heard and allocated. Your personal information will be redacted to retain privacy.

**DECLARATION**

By signing this application, you agree the information provided is true and correct to the best of your knowledge and you are authorised to make this application on behalf of the organisation. You also agree to account for the funding as per the guidelines set out in the Grants Policy.



Signature of primary contact

13 may 2026

Date



Signature of secondary contact

13 may 2026

Date

**57**

**11 KARAKIA WHAKAMUTUNGA – CLOSING**

Kua mutu ā mātou mahi  
Mō tēnei wā  
Manaakitia mai mātou katoa  
O mātou hoa  
O mātou whānau  
Aio ki te Aorangi

Our work is finished  
For the moment  
Blessing upon us all  
Our friends  
Our families  
Peace to the Universe